

Rugged Tablet PC **751**

Features

- Intel® Atom Bay Trail-I processor
- 10.4" XGA TFT LCD with Resistive-type touch screen
- Wi-Fi, Bluetooth 4.0, 4G LTE or 3G
- Smart card and RFID Combo drive
- 8 Programmable keys
- Fan-less design, Thick<28mm, Weight <1.3kg
- Windows 7 / Window 8.1
- MIL-STD-810G, IP54, Drop resistant 4ft



Solution for

- Field Service
- Health Care
- Hospitality
- Logistics
- Transportation
- Utility



Rugged Tablet PC 751

Processor	Intel® Bay trial-I E3825 1.33 GHz Dual Core Processor	Dimension & Weight	Dimension : 275 x 198 x 28 mm (without Bumper) Weight : 1.3kg, with Battery Pack
LCD Panel	10.4" XGA TFT LCD (LED backlight) with Resistive-type touch screen Sunlight readable	Operating System	Windows 7 / Window 8.1
Memory	4GB DDR3L 1066MHz Memory	EMI/Safety	EMI: CE, FCC class B Safety: cUL
Storage	SATA 3Gb mSATA, up to 128GB SSD	Accessory	Service DVD, Adapter, Power cord
Audio	2 x Internal Speaker & 1 x Internal Microphone	Operating & Stock Condition	Operating: -20°C to +50°C Storage: -40°C~80°C Cold boot: 0°C, battery > 75% charge
I/O Port	1 x USB 3.0 3 x USB 2.0 1 x Audio out 1 x MIC in 1 x RJ45 1 x VGA 1 x RS232 1 x Cradle connector 1 x DC-in	Durability Feature	IP54 3 feet drop

Expansion slot	SD/MMC/MS slot, SIM card slot
Communication	802.11 b/g/n WLAN Bluetooth 4.0 class II WWAN (HSPA/E-GPRS/GPS)

Internal Camera	Front : 2 Mega Pixels Camera Rear : 2 Mega Pixels Camera or 5 Mega Pixels
------------------------	---

Option Device Bay	Smart Card and RFID Combo drive or 2nd battery
--------------------------	---

Power System	AC power input: 19V/60W (100~240V)
---------------------	------------------------------------

Battery	27.82Wh Li-ion Battery Packs Battery Hot Swap (Need 2nd Battery)
----------------	---

Button Key	Power button F1, F2, F3, F4, F5, F6, F7, F8 (Function Keys : Brightness, Volume, Screen rotation, RF on/off, etc.)
-------------------	--

System Status Indicators	4 LEDs for Power, Storage & Battery, RF
---------------------------------	---

Docking Station/ Cradle	2 x USB 1 x Ethernet 1 x RS232 1 x Power-in Jack 1 x VGA Support VESA / RAM mount
--------------------------------	--

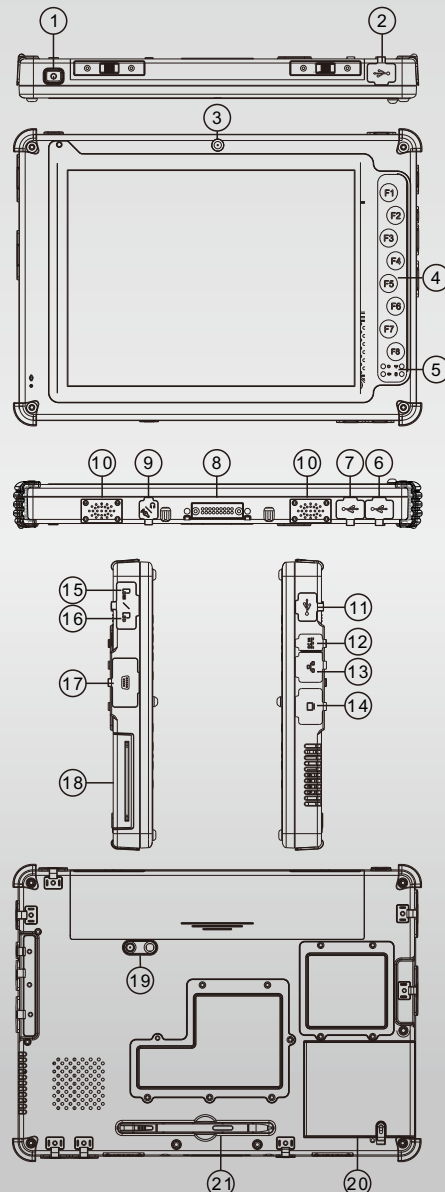

- ① Power Button
- ② USB Port
- ③ 2.0M pixels CMOS Camera
- ④ F1, F2, F3, F4, F5, F6, F7, F8 Function keys
- ⑤ 4 LEDs
- ⑥ USB Port
- ⑦ USB Port
- ⑧ Docking Connector
- ⑨ MIC & Headphone Jack
- ⑩ Stereo Speakers (1.5W x 2)
- ⑪ USB Port
- ⑫ DC-IN Jack
- ⑬ RJ45
- ⑭ VGA Port
- ⑮ SIM Card
- ⑯ SD Card
- ⑰ RS232
- ⑱ Door of Device Bay
- ⑲ 2M pixels Camera + LED light
- ⑳ Device Bay
- ㉑ Stylus